

Plaster Saw „BLUE Power“

dimeda
SURGICAL INSTRUMENTS



Instruction Manual

The plaster saw „BLUE Power“ is an oscillating saw for natural- and synthetic plaster dressings.

In the case of an average plaster size, the 50 mm saw blade should be used. In exceptional cases and if the plaster is thicker, the 65 mm saw blade is required.

For proper changing of the saw blades please use the attached wrenches. It is important that the excenter is not overstrained.

In order to avoid wear and tear as well as any heating of the saw, we highly recommend replacing worn and blunt saw blades in time. Please be aware, that saw blades have sharp cutting edges. This has to be considered during use as well as when replacing them. Caution of injuries!

In case of natural plasters (shiny surface) the appropriate saw blade for natural plasters should be used. In case of synthetic plaster dressings (silky surface) the saw blades for synthetic material should be used. As by cutting synthetic plasters more frictional heat is caused the shavings tend to stick to the saw blade. This effect can be abolished by using specially designed saw blades for synthetic plasters. Those blades have a special surface treatment.

After use any dust or similar should be wiped off the saw and the blade with a dry cloth. The saw should not be soaked in any liquids (like water etc.) or be washed or even covered on. If disinfection is required, it has to be carried out by using appropriate diluted disinfecting solutions. The saw should be only wiped by a damp cloth (do not cover it).

It is important that no liquids or steam enter the equipment. Please unplug the saw before cleaning.

The saw should not be sterilized.

The saw is maintenance-free.

The saw should not be used in areas with danger of explosion.

Before using the saw, it ought to be checked for any mechanical damage. Furthermore, the saw should not be used and has to be sent for a supervision, if it has been dropped onto the floor. Please do not tempt to repair it, as this will void your warranty and additional defects may occur.

In order to assure proper disposal, the plaster saw can be disposed by us or third parties.

Blunt saw blades have to be disposed off by using the recycling process (steel-/ metal raw materials).

The plaster saw is switched by an off/on switch. By switching on the plaster saw a high running-up electricity is effected for a short time. The electronic system avoids that the fuses will adversely react (overload protection switch). After the warming-up to the selected frequency of oscillations, the full power of the saw can be used. If you start your saw carefully, all mechanical and electrical parts will be protected. The risk of injuries is reduced by a smooth starting.

The security switch assures that at no time the plaster saw will be overstrained. In case of overloading, e.g. by blocking the drive, the motor will be switched off immediately. Thanks to the security switch, the plaster saw can be used after a short break by pushing the pin from the overload protection switch.

The plaster saw is developed in accordance with EMV norm EN 60601-1-2.

The regulation of the motor performance is on the rear of the motor (close to the cable connection) and therefore won't disturb the user during use. At the control button the frequency of oscillations required can be infinitely variably selected from 10000 up to 19000.

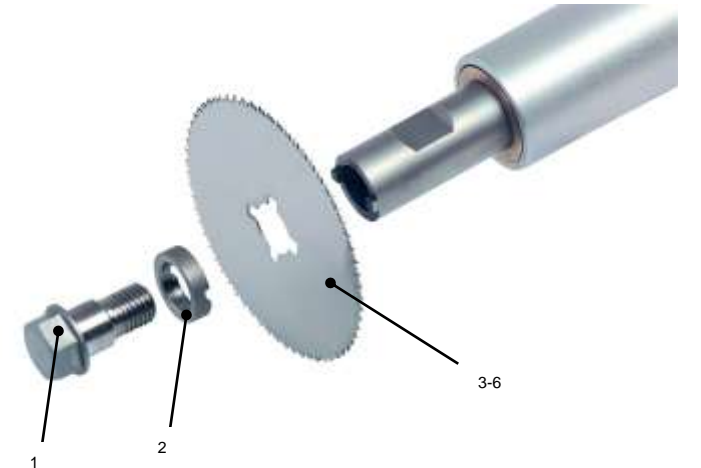

Plaster Saw „BLUE Power“

dimededa[®]
SURGICAL INSTRUMENTS



By using the latest electronic system and electrical parts we are able to offer you a slim motor with a user friendly housing. Furthermore ergonomic and anthroposopic aspects have been considered in respect of smaller hands, noiseless during use (as not to frighten children while cutting the plaster, we recommend a lower number of oscillations).

The ambiental temperature for storing and transportation should not fall below 5 °C and not exceed 40°C. Furthermore humidity should not exceed 80%.

Technical data / classification

Part.-Nr. 30.240.00, plaster saw = 230 V, 50 Hz, 210 W

Part.-Nr. 30.240.01, plaster saw = 120 V, 60 Hz, 210 W

The equipment is in accordance with classe II and typ BF.





Technical Specification

- 230 V, 50 Hz, 210 W or 120 V, 60 Hz, 210 W
- infinitely variable from 10000 up to 19000 oscillations, regulation from outside of the manual operating area
- latest electronic system with various protection and security functions
- 3 m cable with EU-connection
- special positioning of the motor, protected by plaster dust
- reinforced armature shaft
- slim motor edition with silent motor 50 – 72 dB(A) in relation to the selected number of oscillations

Pos. Spare parts and recommended accessories

- 1 pc. fixation screw for saw blade
- 1 pc. fixation ring for saw blade
- 1 pc. spare saw blade, synthetic plaster, 50mm
- 1 pc. spare saw blade, synthetic plaster, 65mm
- 1 pc. spare saw blade, natural plaster, 50mm
- 1 pc. spare saw blade, natural plaster, 65mm
- 1 pair of wrenches

Symbol

-  double protection isolation according to class II
-  medical use of typ BF
-  alternating current
-  CE conformity
- 0/1 Power switch Off / On

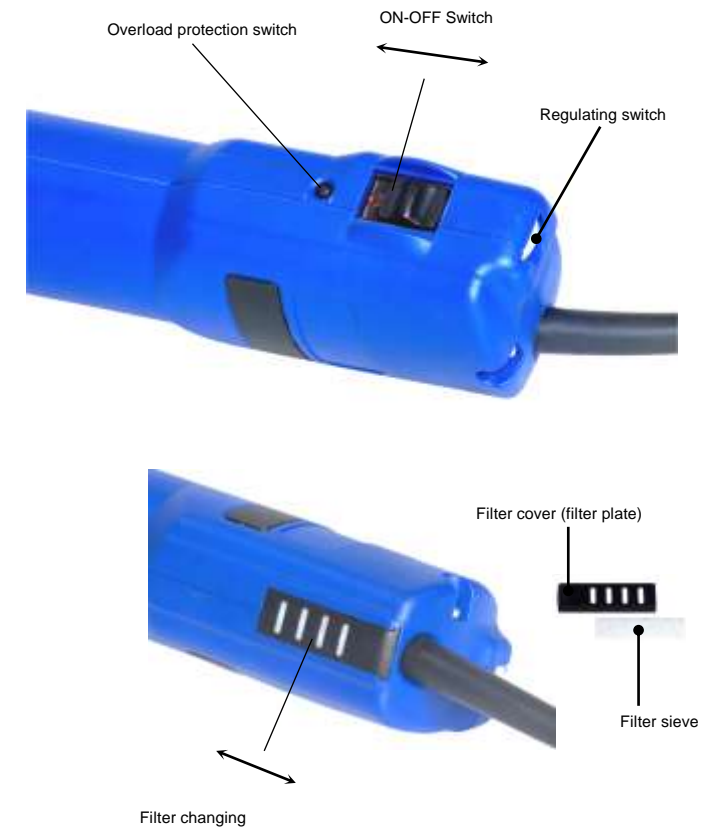

Manufactured by:
MST-Instrumente GmbH
In Breiten 13
D-78589 Dürbheim / Germany
Tel. +49 (0) 7424 – 905921

Distributed by:
Dimeda Instrumente GmbH
Gänsäcker 54+58
D-78532 Tuttlingen / Germany
Tel. +49 (0) 7462 – 946113

Revision A